

Vous rendre sur notre site internet le [www.zitta.ca](http://www.zitta.ca) pour la dernière mise à jour de ce document et voir un vidéo sur la procédure d'installation du produit. Vidéo d'installatoon seulement disponible pour certain produit.

Visit our website at [www.zitta.ca](http://www.zitta.ca) for the last update of this document and see a video about the installation procedure. Installation videos only available for some products.

## Double Slider NIX 48" Double Slider NIX 60"

### ZITTACLEAN

Le micro film protecteur formé lors de son application, fera perler l'eau sur le verre afin d'en faciliter l'entretien.

Il est recommandé de passer la raclette après chaque usage.

The micro protective layer formed during its application will make the water bead along the glass for easy maintenance.

We recommend cleaning the door with the squeegee after each use.

**L'ENTRETIEN DE VOTRE DOUCHE**  
Ne jamais utiliser de poudre ou de tampon à récurer. Il suffit de nettoyer la porte avec une solution d'eau et vinaigre, 1 once vinaigre pour 5 onces d'eau. Vous pouvez utiliser un détergent doux mais aucun produit à base d'ammoniaque cela pourrait endommager la surface de la vitre.

#### THE MAINTENANCE OF YOUR SHOWER

Never use of powder or scouring pads. Simply clean the door with a solution of water and vinegar, 1 to 5. You can use a mild detergent but never use ammoniac, it could damage the glass surface.

#### PORTE REVERSIBLE / REVERSIBLE DOOR

Les instructions montrés au manuel sont pour le montage de la porte droite. The instructions shown in the manual is for the installation of the right door.



ACRYLINE

Tel: 1-855-492-4242 450-704-2323

Fax: 1-866-735-6885

Info@zittagroup.com

[www.zittagroup.com](http://www.zittagroup.com)

81, Theodore-Viau, Terrebonne,  
Quebec, Canada, J6Y 0J8

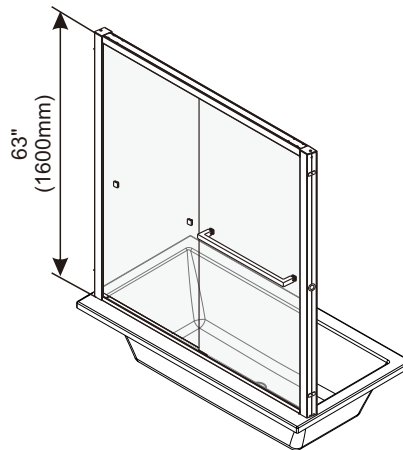
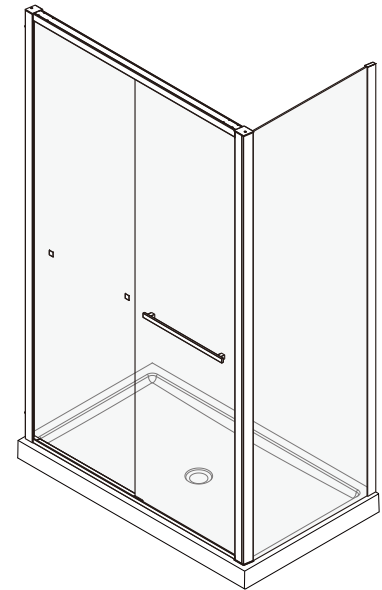
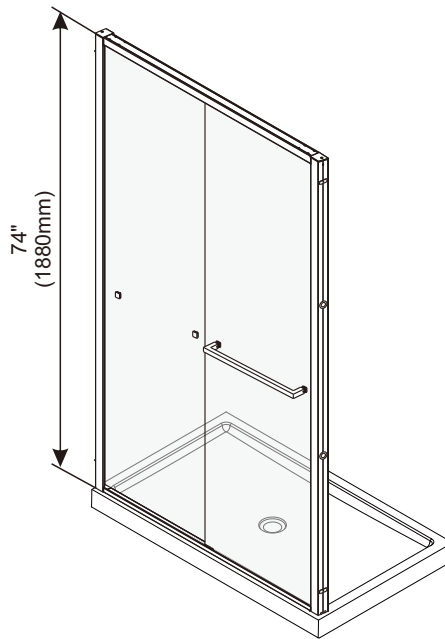

## MANUEL D'INSTALLATION / INSTALLATION MANUAL

### IMPORTANT

- Inspecter le produit avant de procéder à l'installation.
- La garantie sera invalide si le produit a été installé avec des défauts apparents.

### ATTENTION

- Lors de l'installation, l'application de silicone doit être à l'extérieur de la douche, car si appliqué à l'intérieur, cela peut causer des fuites d'eau !
- Veuillez lire attentivement ce manuel d'instruction avant de commencer l'installation.
- Conserver ce manuel pour référence ultérieure.

### IMPORTANT

- Thoroughly inspect your product before proceeding with the installation.
- The warranty will be void if the product is installed with a conspicuous defect.

### CAUTION

- To prevent leaks, silicone must be applied on the outside of the shower and not on the inside!
- Read all instructions carefully before starting the installation.
- Save this manual for future reference.

# PORTE DOUBLE COULISSANTE NIX / NIX DOUBLE SLIDER DOOR

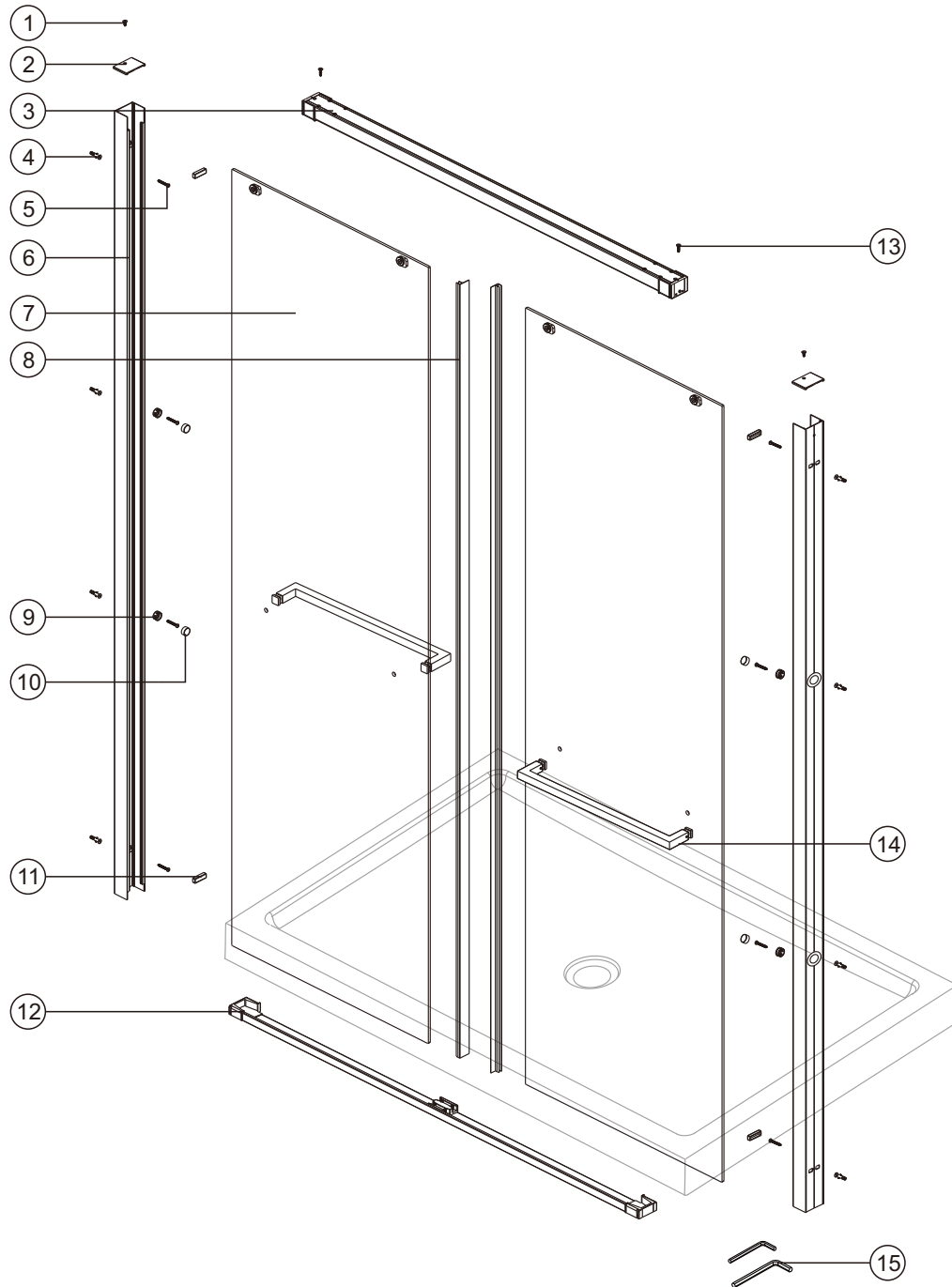

| Numéro NO | Qté Qty | Description Description                                | 48" Chrome/Chrome | 60" Chrome/Chrome | 48" Noir/Black | 60" Noir/Black | Numéro NO | Qté Qty | Description Description                                      | 48" Chrome/Chrome | 60" Chrome/Chrome | 48" Noir/Black | 60" Noir/Black |
|-----------|---------|--|-------------------|-------------------|----------------|----------------|-----------|---------|--|-------------------|-------------------|----------------|----------------|
| 1         | 2       | Vis 4X14 / Screw 4X14                                  | PV001499          | PV001499          | PV001497       | PV001497       | 9         | 4       | Support de capuchon de vis / Screw cap support               | PQ002902          | PQ002902          | PQ002907       | PQ002907       |
| 2         | 2       | Capuchon d'extrusion murale / Wall extrusion cover cap | PQ039402          | PQ039402          | PQ039407       | PQ039407       | 10        | 4       | Capuchon de vis / Screw cap                                  | PQ002902          | PQ002902          | PQ002907       | PQ002907       |
| 3         | 1       | Système de guide du haut / Top guide system            | PQ039902          | PQ039502          | PQ039907       | PQ039507       | 11        | 4       | Amortisseur de porte / Door bumper                           | PQ039699          | PQ039699          | PQ039697       | PQ039697       |
| 4         | 8       | Cheville murale / Wall anchor                          | PV000199          | PV000199          | PV000199       | PV000199       | 12        | 1       | Système de guide du bas / Bottom guide system                | PQ040002          | PQ039702          | PQ040007       | PQ039707       |
| 5         | 8       | Vis 4X40 / Screw 4X40                                  | PV000799          | PV000799          | PV000799       | PV000799       | 13        | 2       | Vis 4X8 / Screw 4X8  | PV002899          | PV002899          | PV002899       | PV002899       |
| 6         | 2       | Extrusion murale / Wall extrusion                      | PA007402          | PA007402          | PA007407       | PA007407       | 14        | 2       | Poignée de porte / Door handle                               | PP002702          | PP002702          | PP002707       | PP002707       |
| 7         | 2       | Panneau de porte / Door panel                          | PG018420          | PG018220          | PG018420       | PG018220       | 15        | 2       | Kit de clé Allen 2.5mm & 4.0mm / 2.5mm & 4.0mm Allen key kit | PT002899          | PT002899          | PT002899       | PT002899       |
| 8         | 2       | Joint d'étanchéité de porte / Door gasket              | PJ017710          | PJ017710          | PJ017717       | PJ017717       |           |         |  |                   |                   |                |                |

# PORTE DOUBLE COULISSANTE NIX / NIX DOUBLE SLIDER DOOR

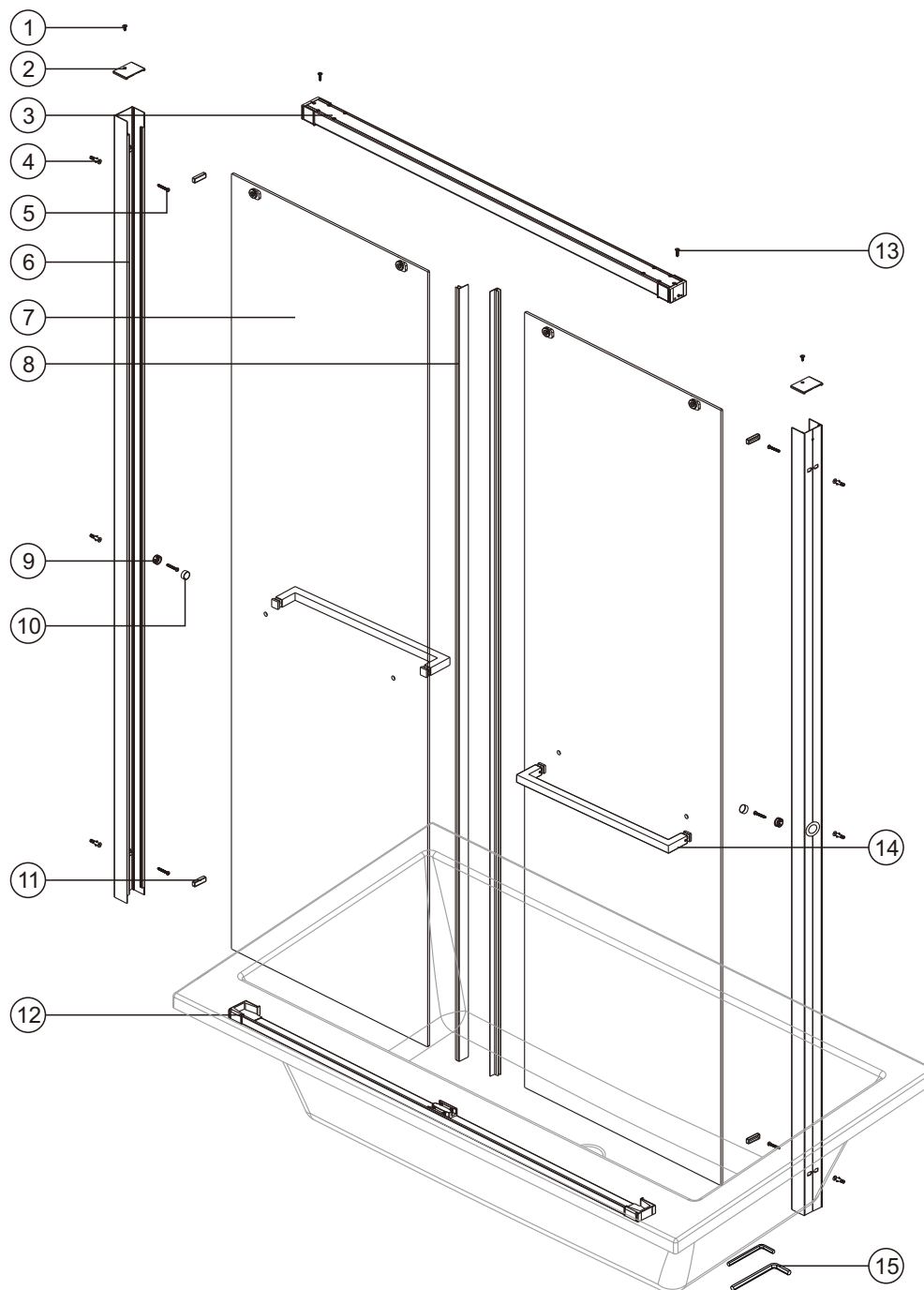

| Numéro NO | Qté Qty | Description Description                                | 60" bathtub Baignoire 60" Chrome/Chrome | 60" bathtub Baignoire 60" Noir/Black | Numéro NO | Qté Qty | Description Description                                      | 60" bathtub Baignoire 60" Chrome/Chrome | 60" bathtub Baignoire 60" Noir/Black |
|-----------|---------|--|---|--------------------------------------|-----------|---------|--|---|--------------------------------------|
| 1         | 2       | Vis 4X14 / Screw 4X14                                  | PV001499                                | PV001497                             | 9         | 2       | Support de capuchon de vis / Screw cap support               | PQ002902                                | PQ002907                             |
| 2         | 2       | Capuchon d'extrusion murale / Wall extrusion cover cap | PQ039402                                | PQ039407                             | 10        | 2       | Capuchon de vis / Screw cap                                  | PQ002902                                | PQ002907                             |
| 3         | 1       | Système de guide du haut / Top guide system            | PQ039502                                | PQ039507                             | 11        | 4       | Amortisseur de porte / Door bumper                           | PQ039699                                | PQ039697                             |
| 4         | 6       | Cheville murale / Wall anchor                          | PV000199                                | PV000199                             | 12        | 1       | Système de guide du bas / Bottom guide system                | PQ039702                                | PQ039707                             |
| 5         | 6       | Vis 4X40 / Screw 4X40                                  | PV000799                                | PV000799                             | 13        | 2       | Vis 4X8 / Screw 4X8  | PV002899                                | PV002899                             |
| 6         | 2       | Extrusion murale / Wall extrusion                      | PA007502                                | PA007507                             | 14        | 2       | Poignée de porte / Door handle                               | PP002702                                | PP002707                             |
| 7         | 2       | Panneau de porte / Door panel                          | PG018320                                | PG018320                             | 15        | 2       | Kit de clé Allen 2.5mm & 4.0mm / 2.5mm & 4.0mm Allen key kit | PT002899                                | PT002899                             |
| 8         | 2       | Joint d'étanchéité de porte / Door gasket              | PJ017810                                | PJ017817                             |           |         |  |   |                                      |

# PORTE DOUBLE COULISSANTE NIX / NIX DOUBLE SLIDER DOOR

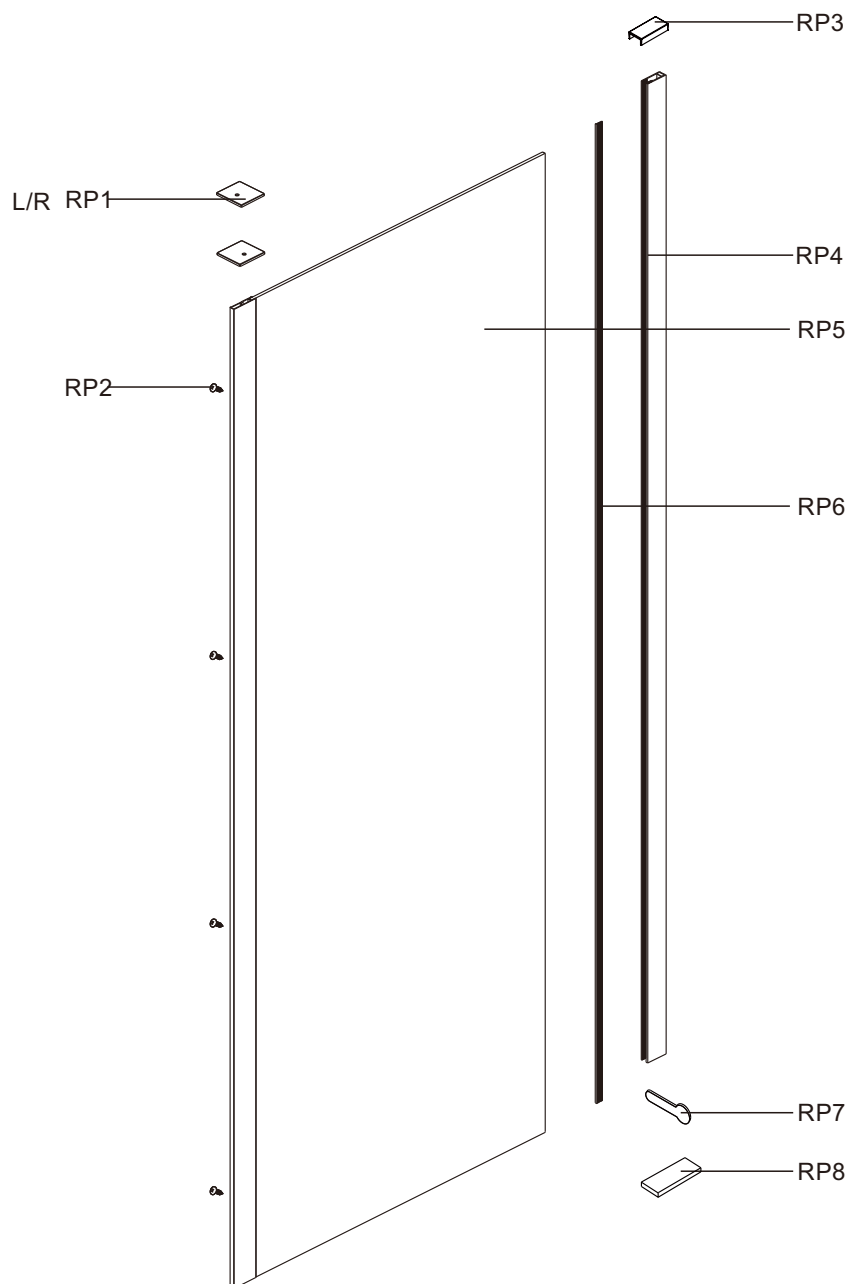

| Numéro NO | Qté Qty | Description Description                                | 32" Chrome/Chrome | 36" Chrome/Chrome | 32" Noir/Black | 36" Noir/Black |
|-----------|---------|--|-------------------|-------------------|----------------|----------------|
| RP1       | 2       | Cap pour extrusion de coin / Cap for corner profile    | PQ036306          | PQ036306          | PQ036306       | PQ036306       |
| RP2       | 4       | Vis 4X10 / Screw 4X10                                  | PV005599          | PV005599          | PV005599       | PV005599       |
| RP3       | 1       | Capuchon d'extrusion murale / Wall extrusion cover cap | PQ040102          | PQ040102          | PQ040107       | PQ040107       |
| RP4       | 1       | Extrusion murale / Wall extrusion                      | PA007602          | PA007602          | PA007607       | PA007607       |
| RP5       | 1       | Panneau de porte / Door panel                          | PG018520          | PG018620          | PG018520       | PG018620       |
| RP6       | 1       | Joint d'étanchéité de porte / Door gasket              | PJ017910          | PJ017910          | PJ017917       | PJ017917       |
| RP7       | 1       | Outil pour joint de serrage / Squeeze gasket tool      | PT000399          | PT000399          | PT000399       | PT000399       |
| RP8       | 5       | Support d'installation pour vitre / Glass wedge spacer | PT000199          | PT000199          | PT000199       | PT000199       |

## PREPARATION

**A** 01

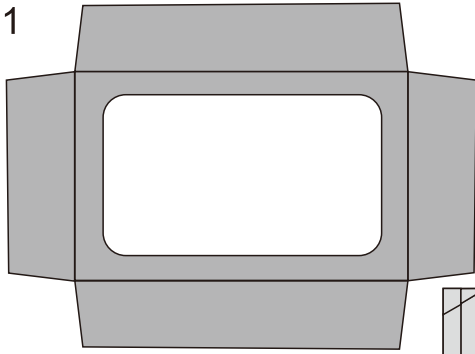

Pour protéger le FINI de votre base de douche.  
To protect your shower base finish.

20~30mm

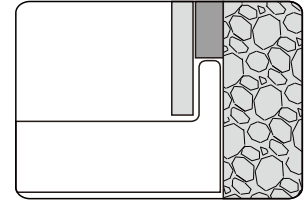



**ATTENTION !**  
Attendre 24h avant d'installer votre porte de douche, afin de permettre au mortier et à la finition de sécher complètement.

**WARNING !**  
Wait 24h before proceeding with the installation of the shower door. This will ensure that the finish and mortar is dry.

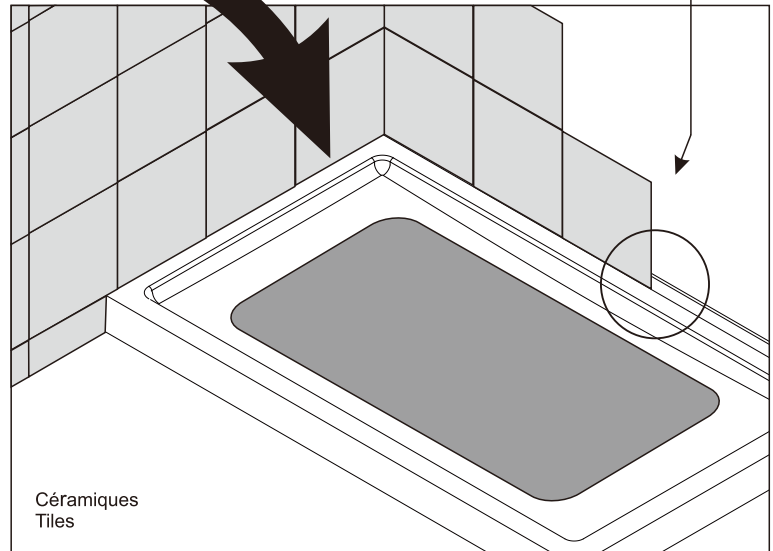

## DIMENSION

**A** 02

48" 45 1/4"(1148mm) - 46 3/4"(1188mm)  
60" 57 1/4"(1453mm) - 58 3/4"(1493mm)

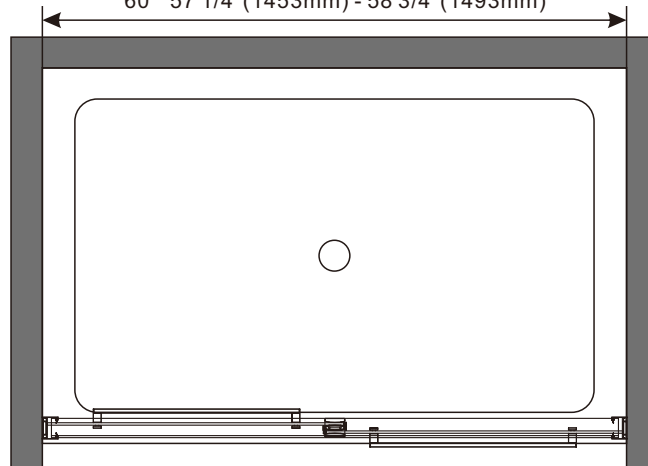

# INSTALLATION DU GUIDE DU BAS / BOTTOM GUIDE INSTALLATION

**A** 02

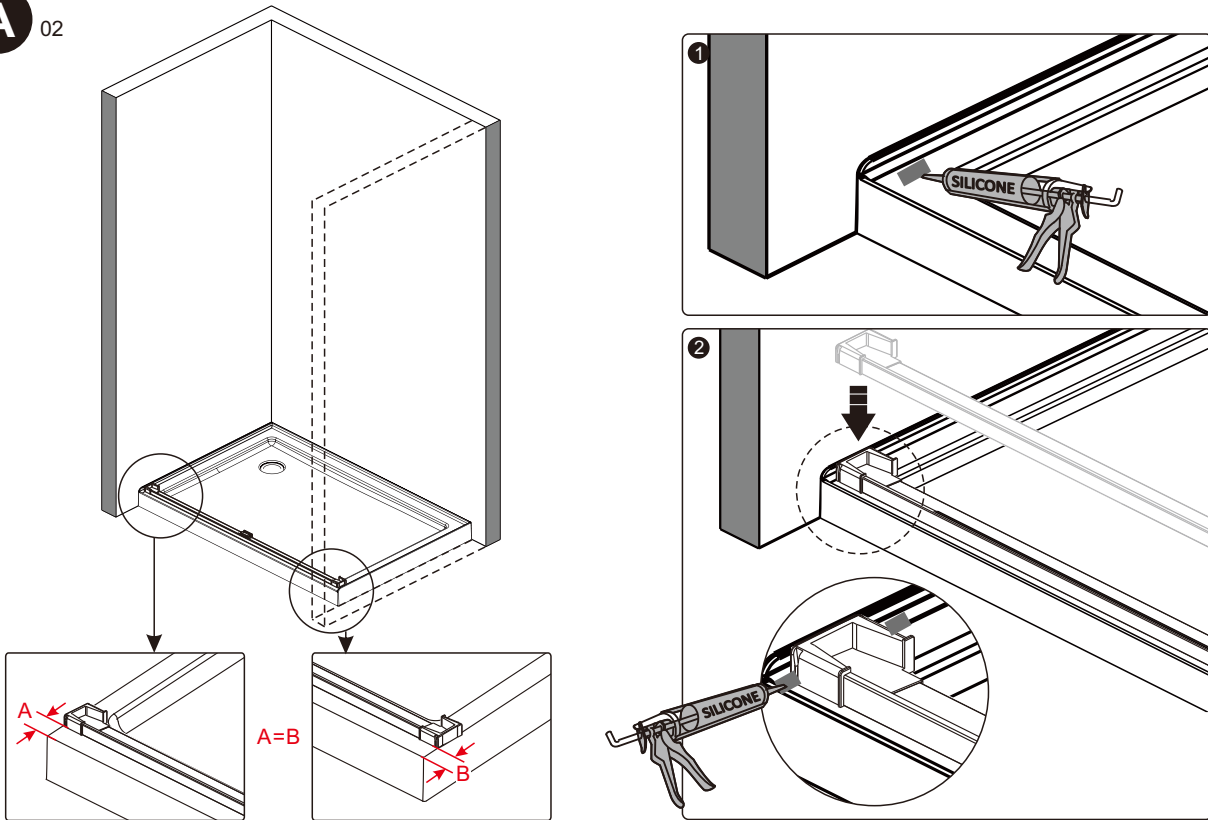

# INSTALLATION DES EXTRUSIONS MURALES / WALL EXTRUSIONS INSTALLATION

**A** 03

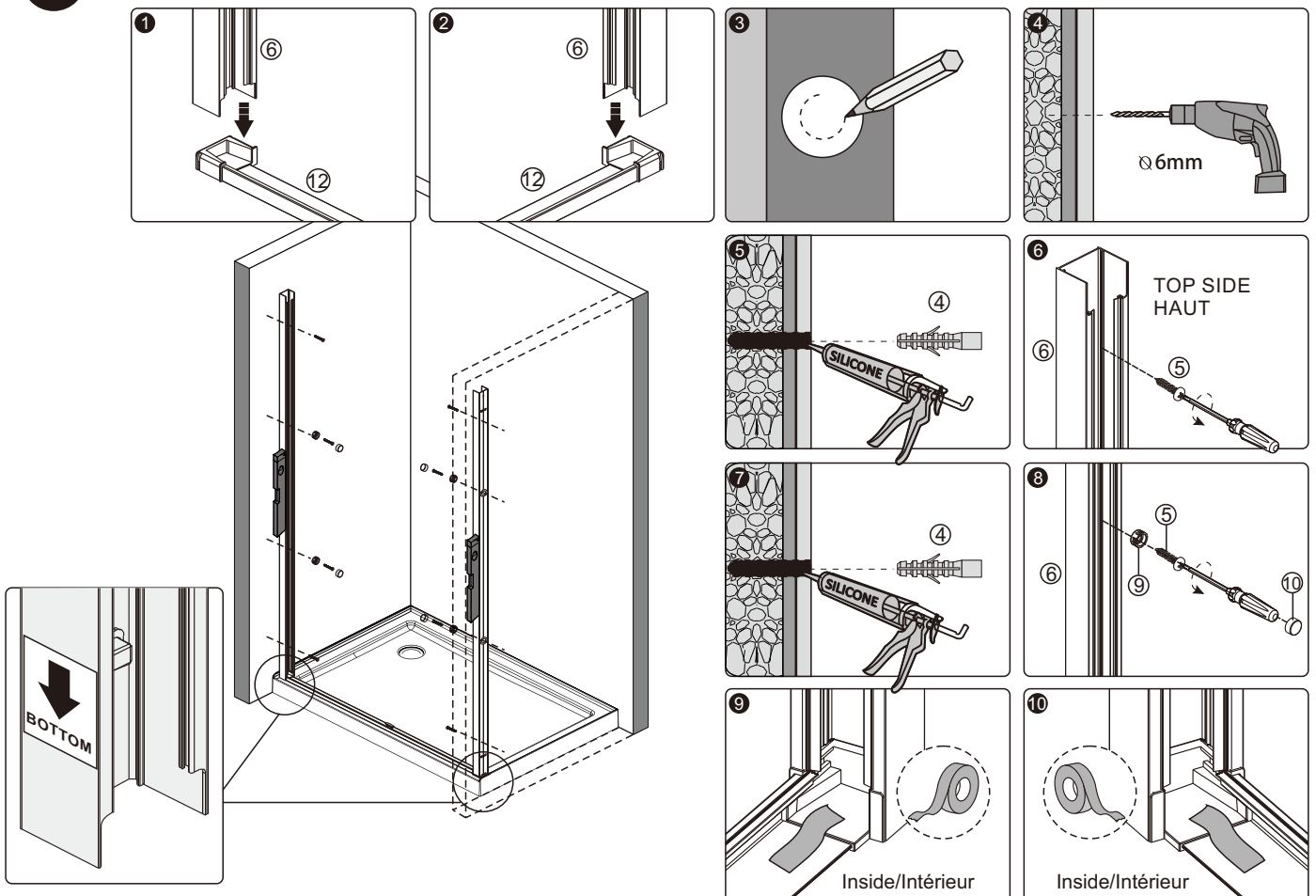

# INSTALLATION DU GUIDE DU HAUT / TOP GUIDE INSTALLATION

**A** 04

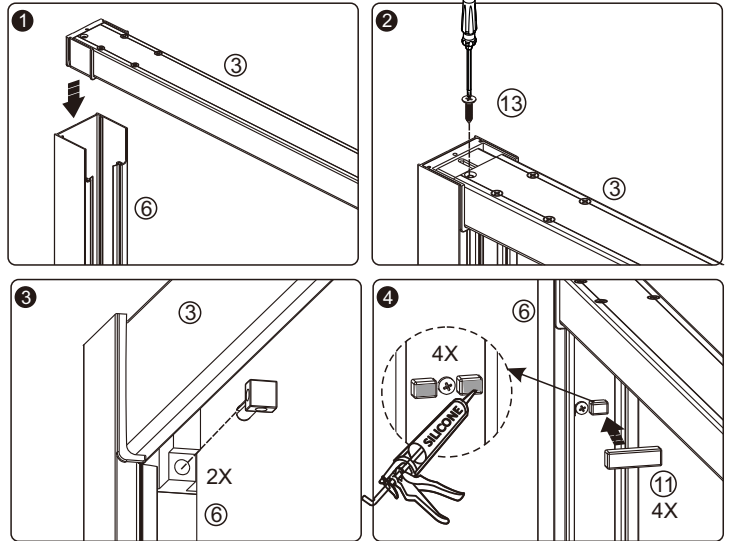
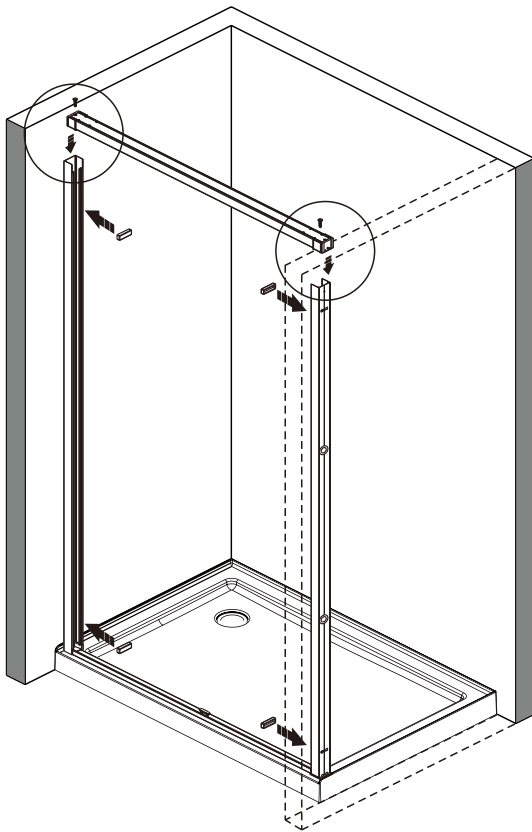

# INSTALLATION DES POIGNÉES DE PORTE / DOOR HANDLES INSTALLATION

**A** 05

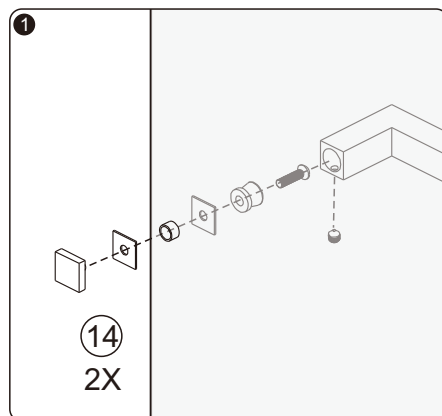
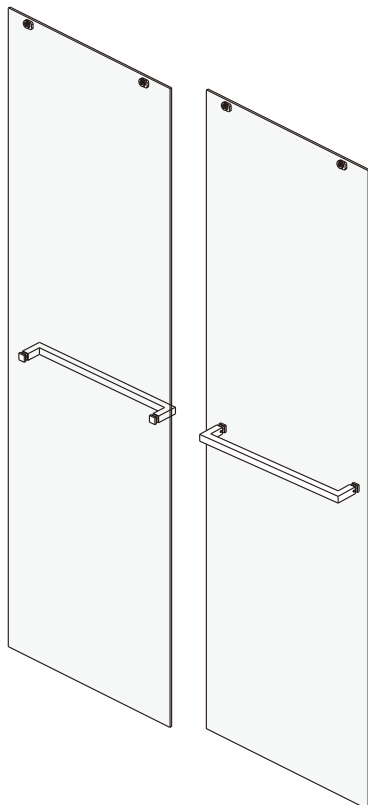

# INSTALLATION DES PORTES / DOORS INSTALLATION

**A** 06

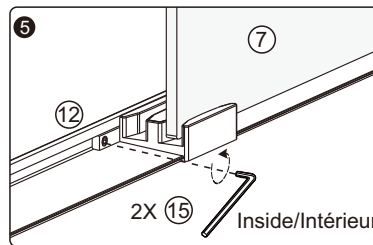
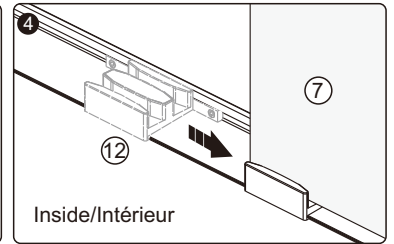
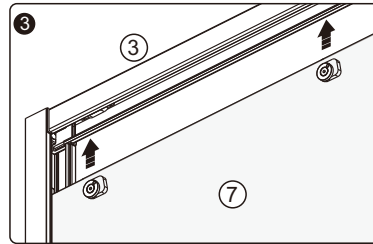
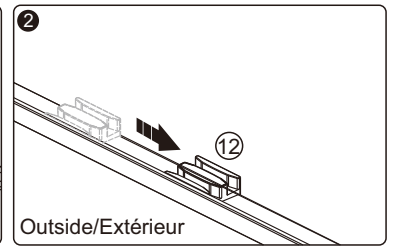
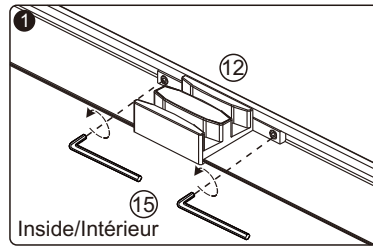
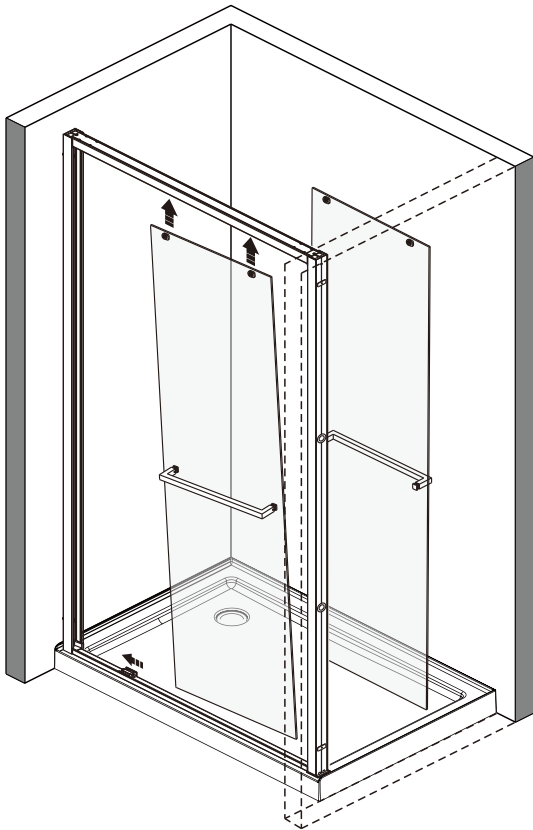

## SUITE / CONTINUED

**A** 07

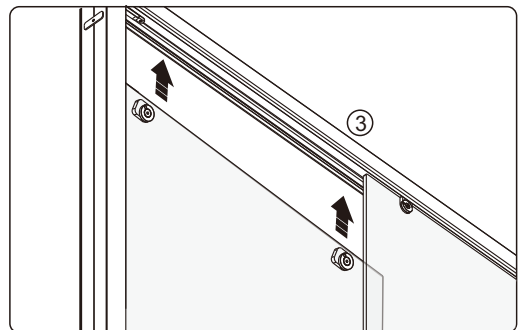
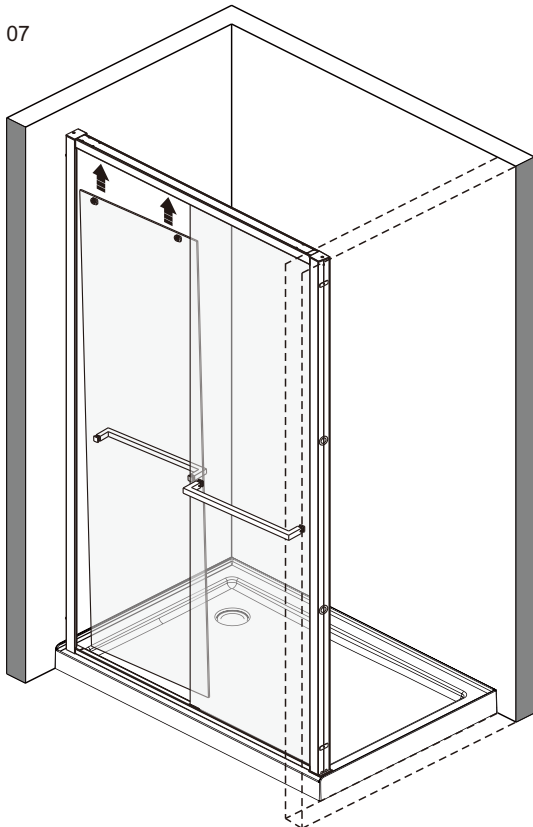



# FINITION ET JOINT D'ÉTANCHÉITÉ / FINISH AND GASKETS

**A** 08

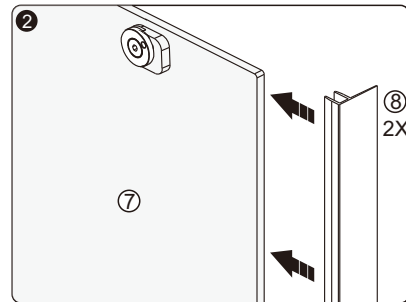
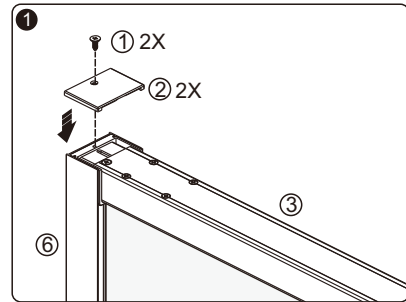
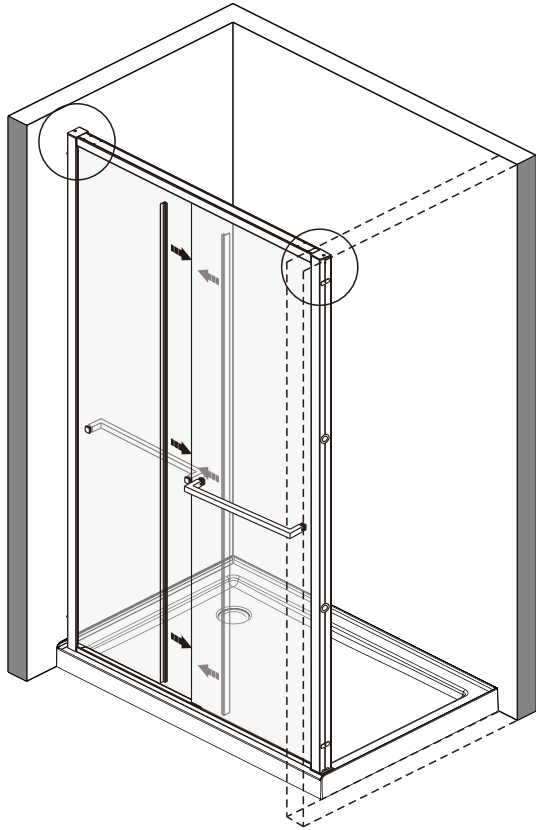

# AJUSTEMENT DES PORTES / DOORS ADJUSTMENT

The flat side of the part must be at the top  
La partie plate de la pièce doit être en haut

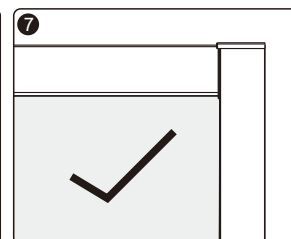
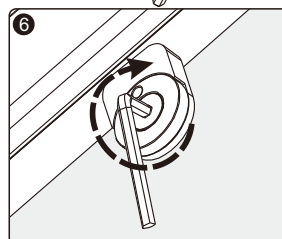
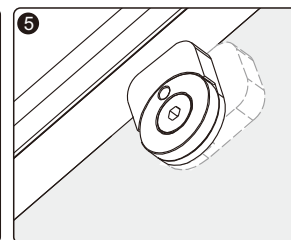
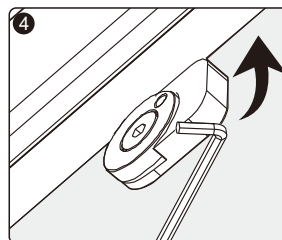
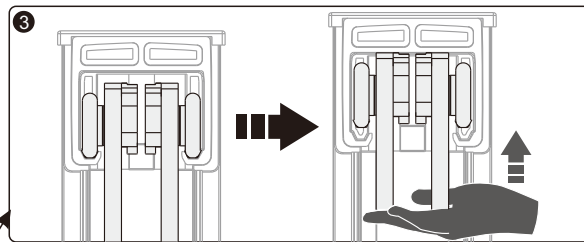
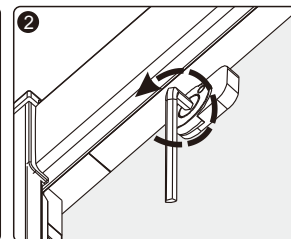
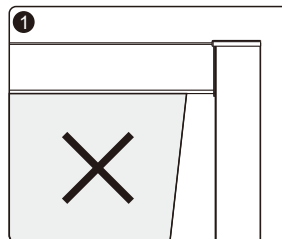
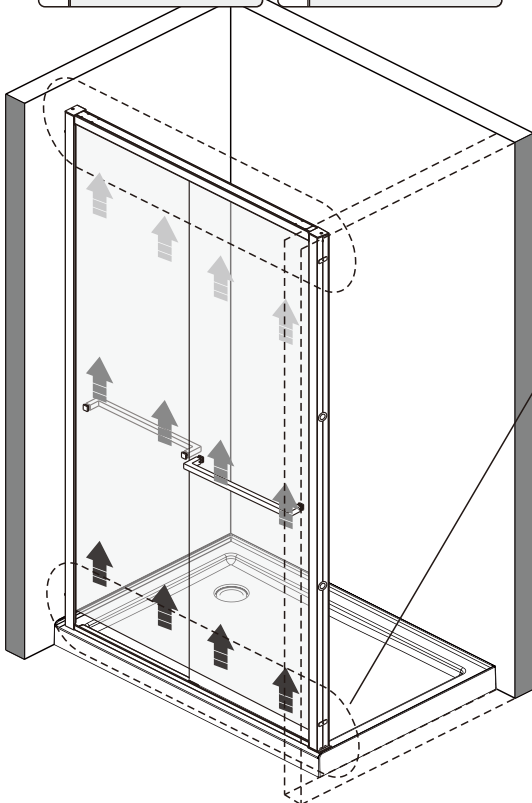
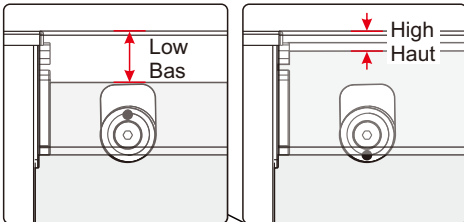

**A** 09

# AJUSTEMENT DES JOINTS D'ÉTANCHÉITÉ / GASKET ADJUSTMENT

**A** 10

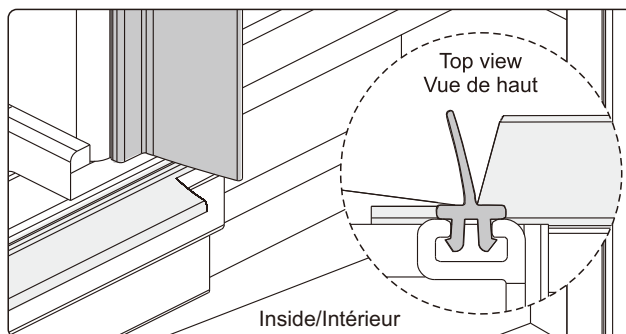
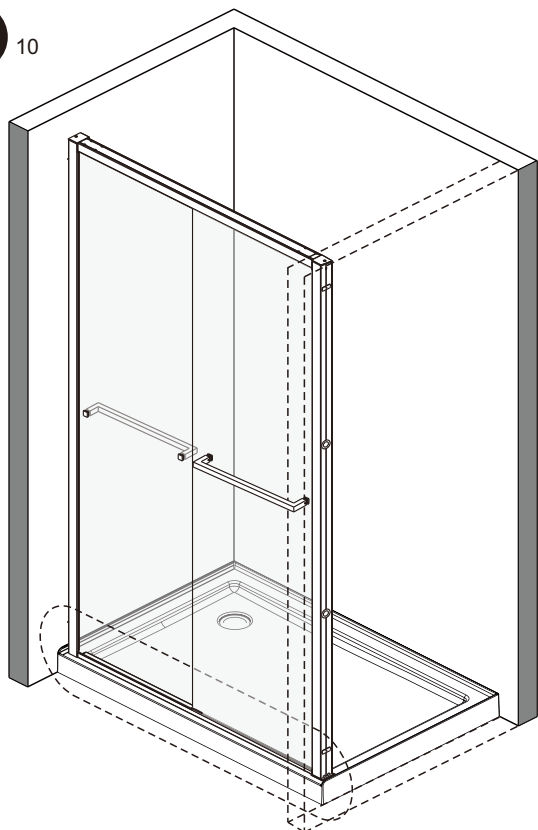

# CALFREUTAGE / CAULKING

**A** 11

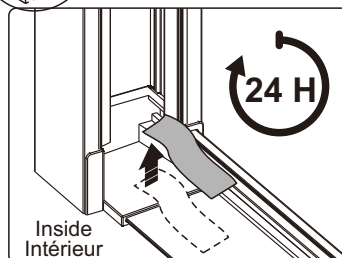
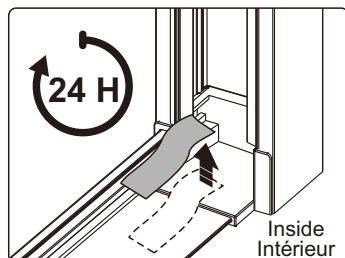
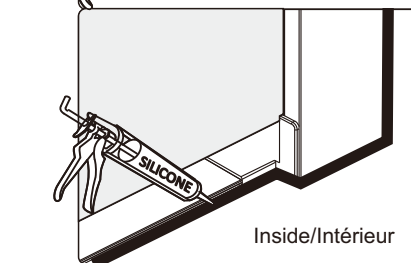
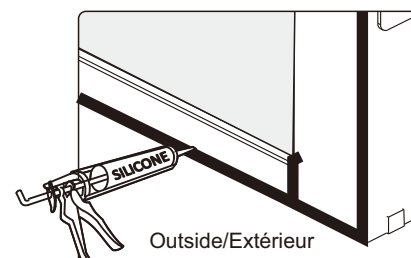
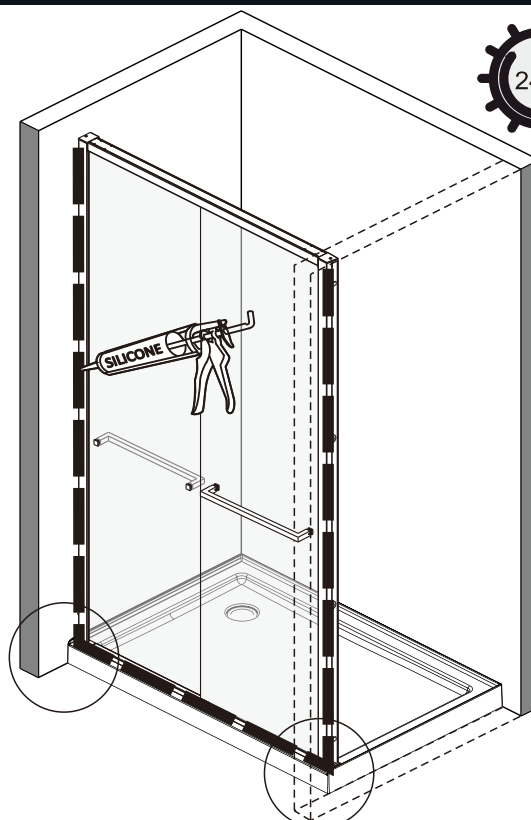
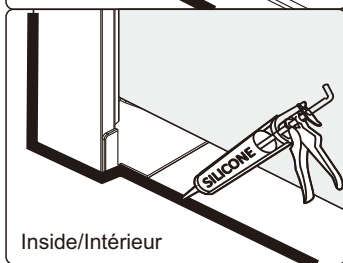

# PREPARATION

**B** 01

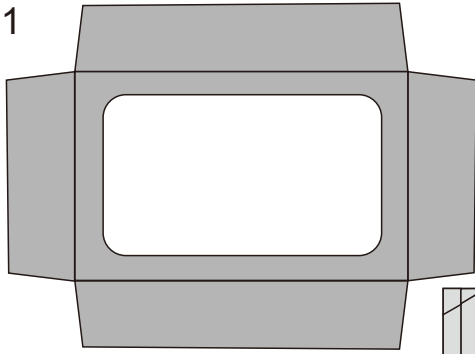

Pour protéger le FINI de votre base de douche.  
To protect your shower base finish.

20~30mm

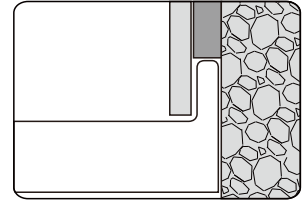

**ATTENTION !**  
Attendre 24h avant d'installer votre porte de douche, afin de permettre au mortier et à la finition de sécher complètement.

**WARNING !**  
Wait 24h before proceeding with the installation of the shower door. This will ensure that the finish and mortar is dry.

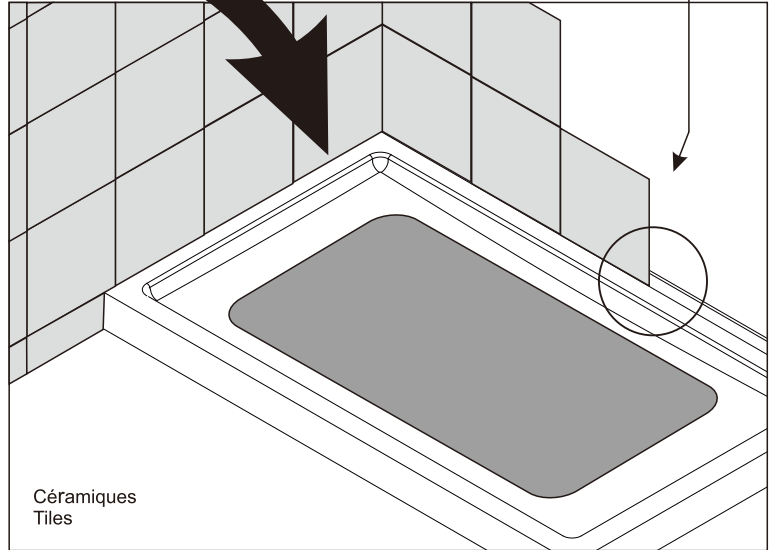

# DIMENSION

**B** 02

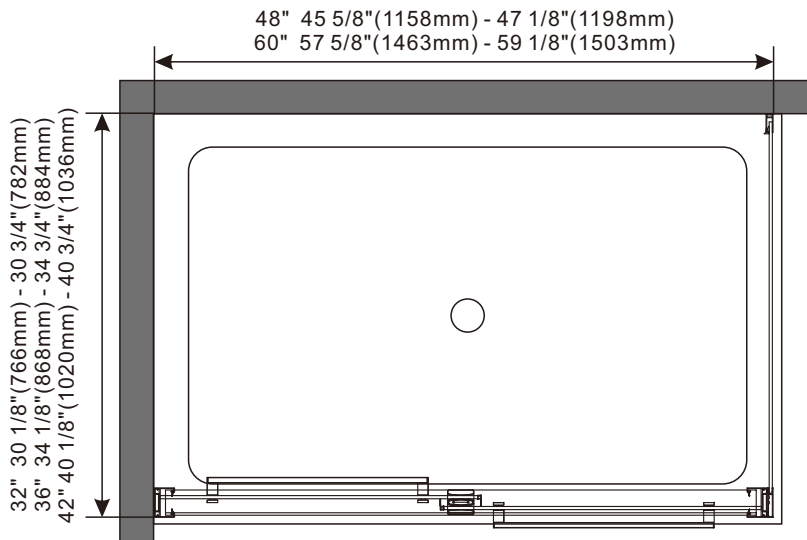

# INSTALLATION DU MONTANT MURAL/WALL CHANEL INSTALLATION

**B** 03

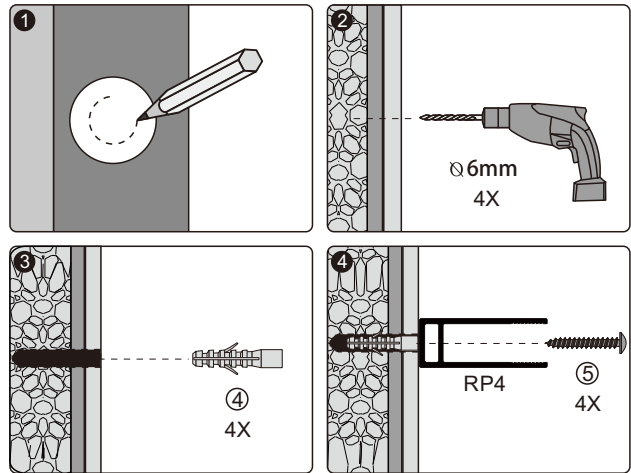
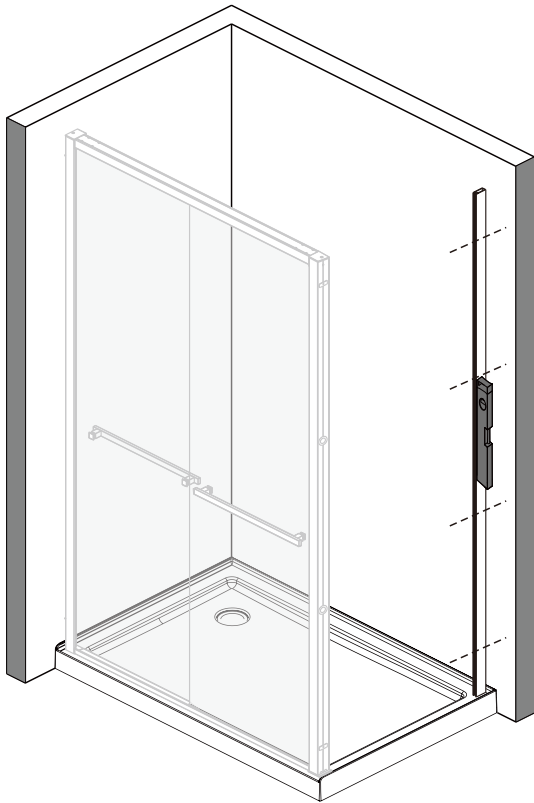

# INSTALLATION DU PANNEAU DE RETOUR/RETURN PANEL INSTALLATION

**B** 04

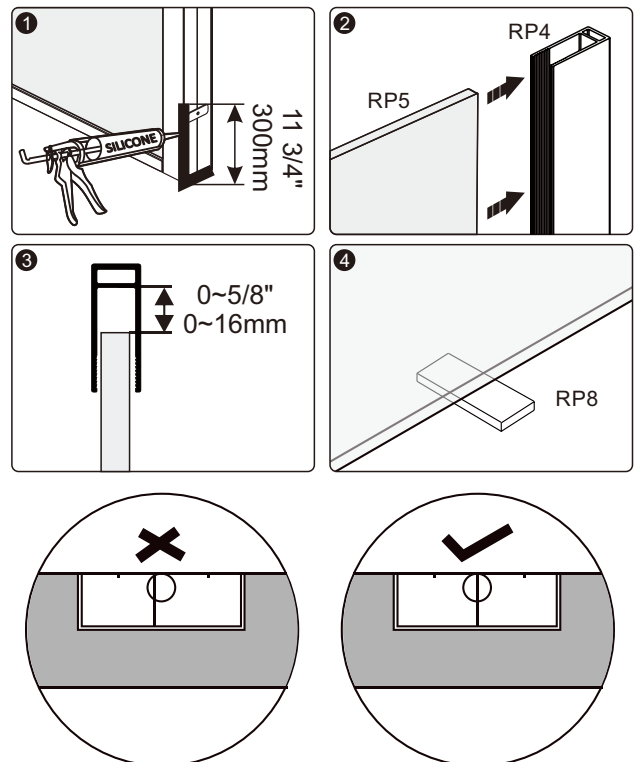
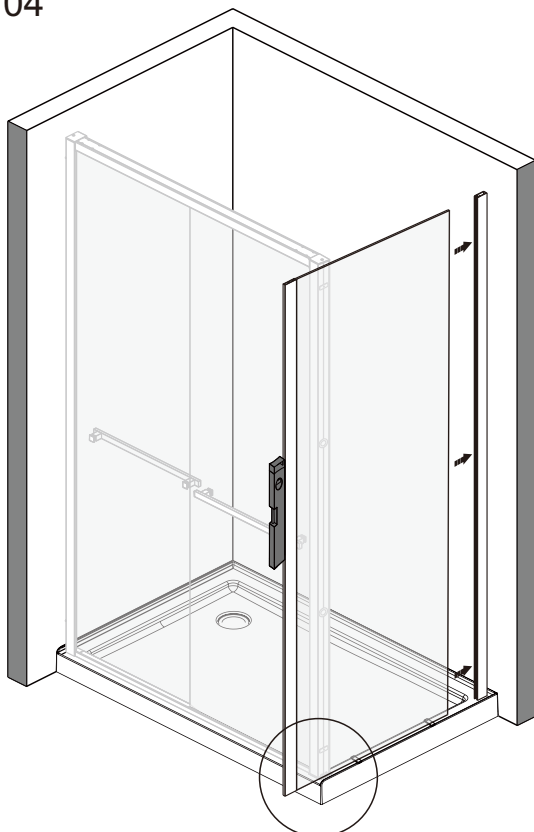

## EXTRUSION DE COIN / CORNER EXTRUSION

**B** 05

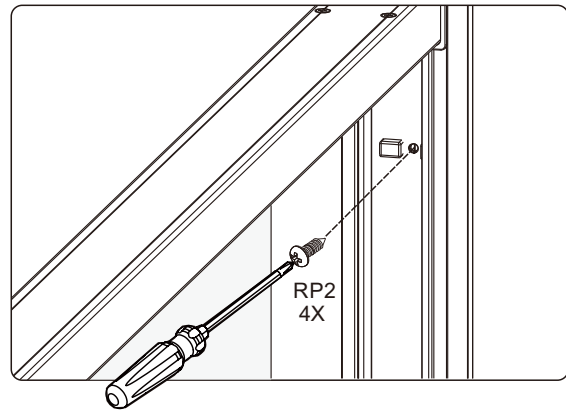
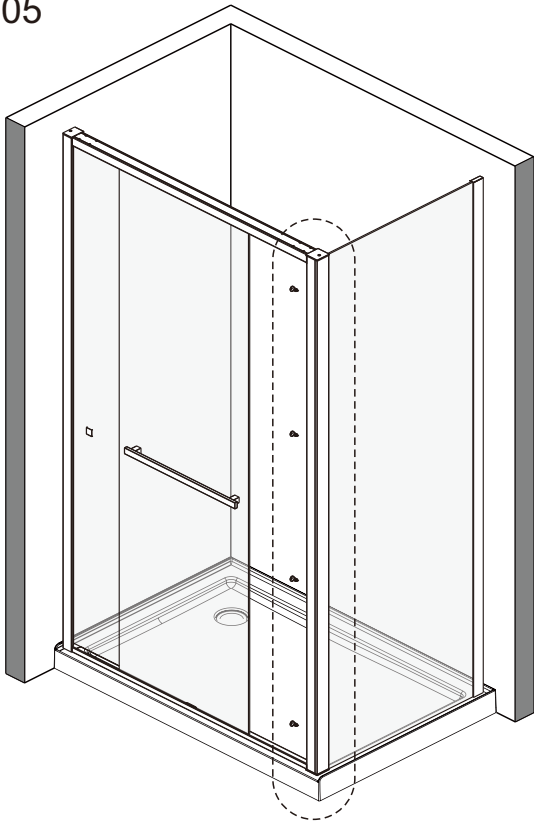

## SUITE/CONTINUED

**B** 06

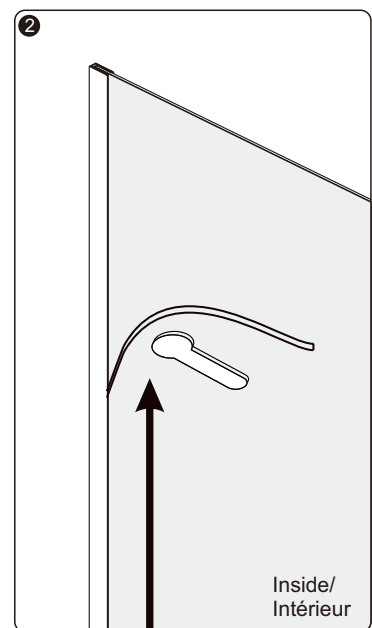
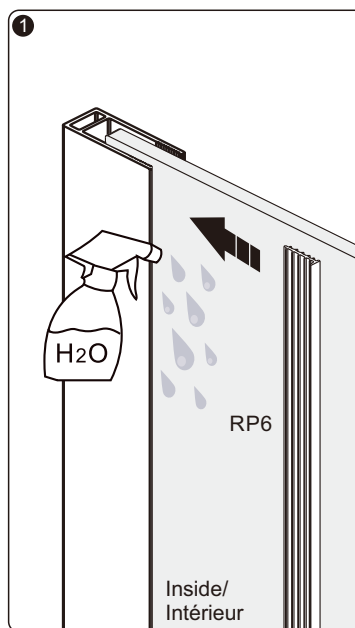
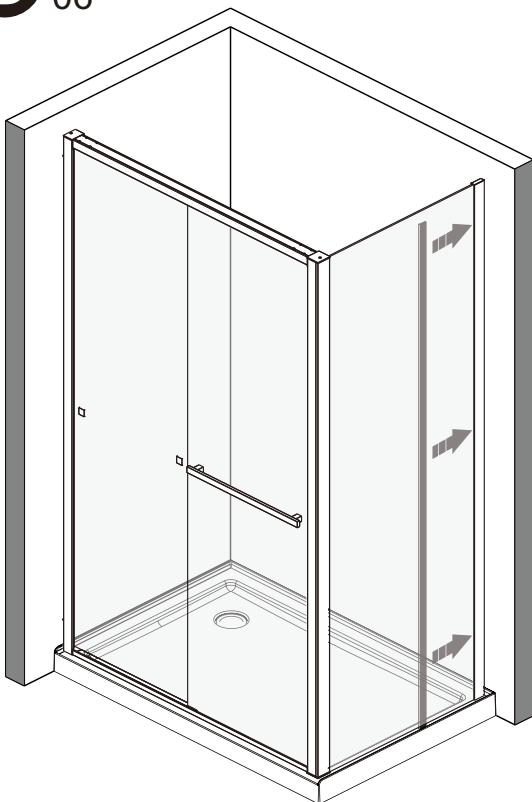

**B** 07

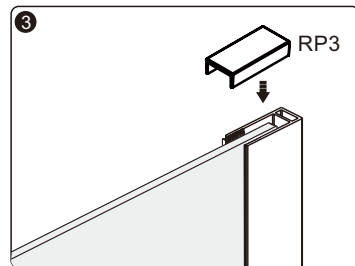
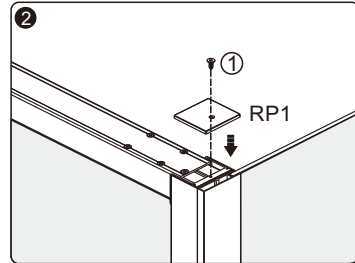
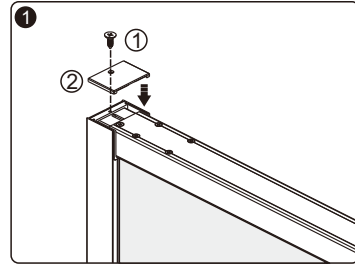
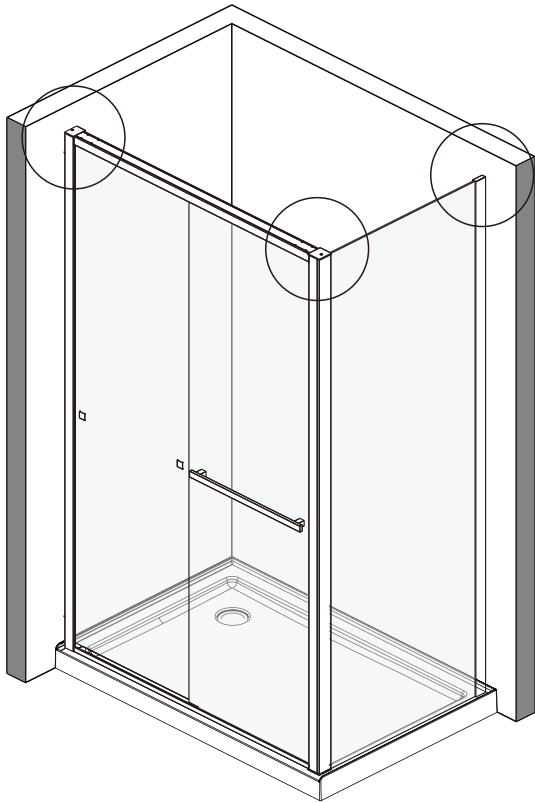

AJUSTEMENT DES JOINTS D'ÉTANCHÉITÉ / GASKET ADJUSTMENT

**B** 08

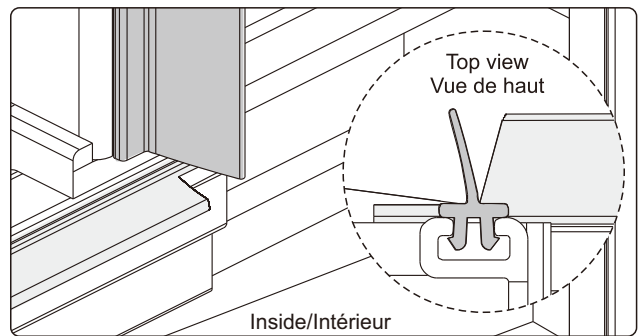
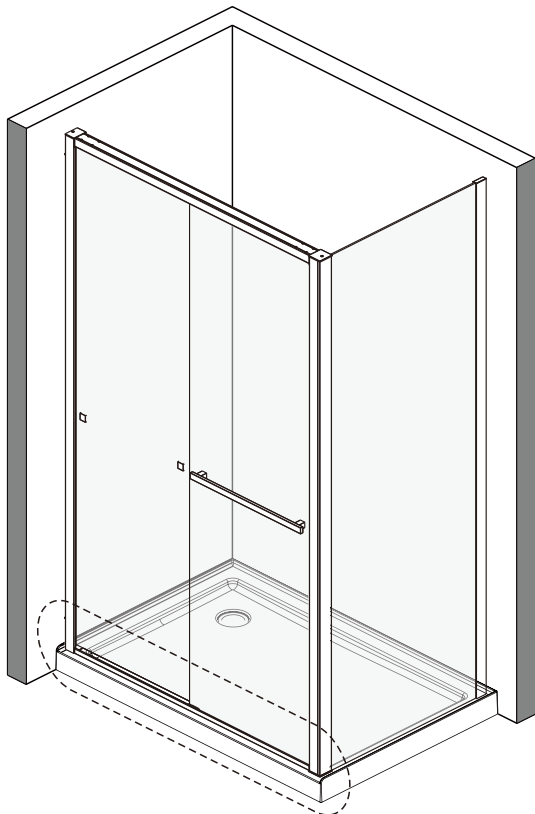

# CALFREUTAGE / CAULKING

**B** 09

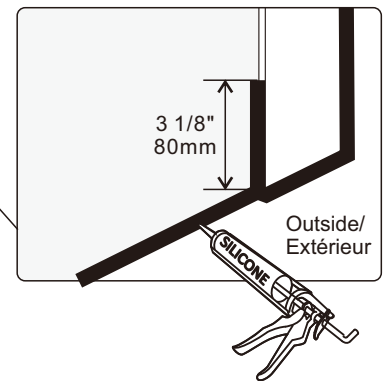
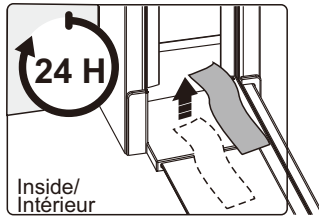
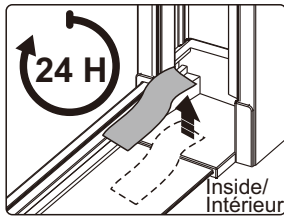
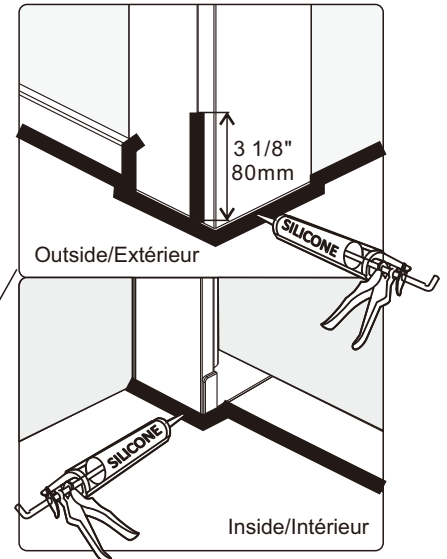
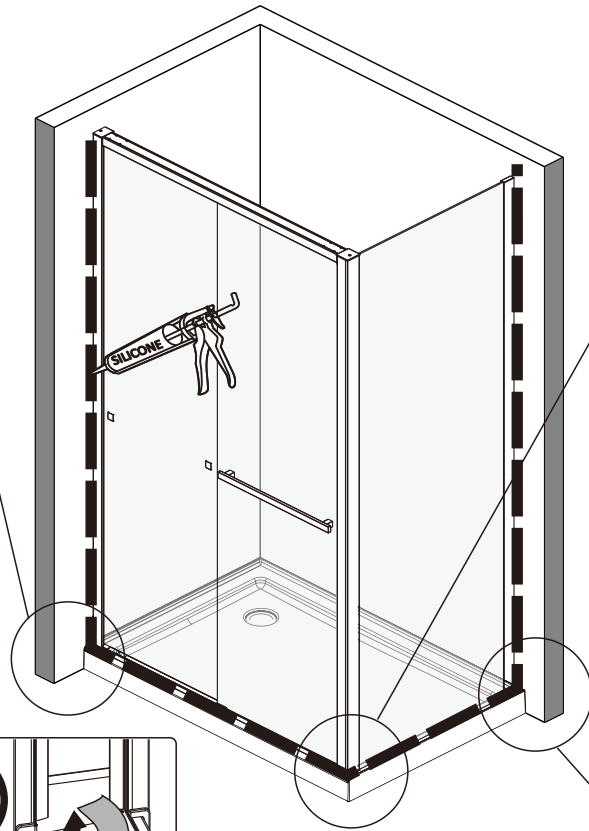
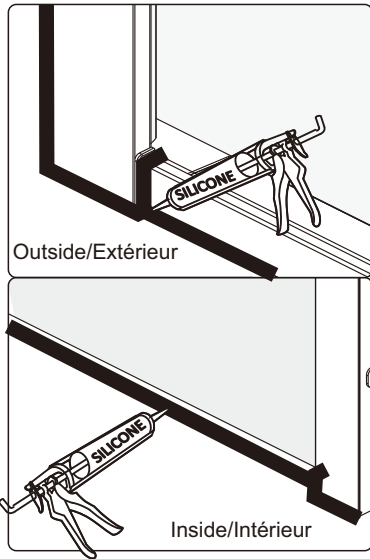

# WARRANTY / GARANTIES

## Warranty Bathtub / Shower

|                                  |          |
|----------------------------------|----------|
| Acrylic                          | 20 years |
| System and composants            | 3 years  |
| ADA and / or commercial products | 1 year   |
| Shower doors                     | 10 years |
| Roller and hinges                | Lifetime |
| Slik stone / solid surface       | 5 years  |
| Slik cast / cast iron            | 25 years |
| ZittaClean                       | 10 years |
| Accessory, drain & niche         | 5 years  |
| Shower column                    | 10 years |
| Electronics                      | 1 year   |

Following the terms and conditions described below, ZittaGroup warrants the product to be free from defects in workmanship from the date of purchase. This warranty applies to the initial date of purchase from an authorized dealer for the owner/end-user only. This warranty cannot be transferred to a third party. This warranty excludes any expenses related to shipping, handling and/or installation fees.

The present warranty does not cover the defects or breaking resulting from any Act of God, accident, catastrophe, abuse, negligence, improper installation, addition or removal of parts or equipment, of misuse, intensive variation of temperature, exposures to chemicals and/or abrasives of any kind, stains caused by different types of water such as ferrous or alkaline water.

ZittaGroup cannot be held responsible for the direct or indirect damage caused by or resulting from fortuitous occurrences, from the expenses of sundries, labor, wastes of time, material or any other cost related to the application or the replacement of the product or one of its components. In the eventuality that a manufacturing defect appears, the owner/enduser must have followed the instructions of installation described in the installation manual, have in his possession the proof of purchase as well as a proof of installation by a professional recognized by the construction industry. ZittaGroup will, at its own discretion, repair or replace the product based on the selling price at the time of purchase. ZittaGroup reserves the right to inspect, on site, the defect by a representative of its choice. Any return of goods will not be accepted without the written authorization from ZittaGroup.

### Care and cleaning

Zitta recommends the use of mild dishwashing liquids or water to keep the surfaces bright and clean. Rinse well and dry with a clean cloth. CAUTION : Powder detergents and liquid abrasive cleaners may damage surfaces. Do not allow the visible surfaces to come in contact with corrosive products such as drain cleaners. DO NOT USE : Cleaning agents that contains chlorides, alcohol, ammonia or mineral essences, steel wool, scouring pad or wire brushes.

## Garantie Baignoire / Douche

|                                  |        |
|----------------------------------|--------|
| Acrylique                        | 20 ans |
| Système et composants            | 3 ans  |
| Produits ADA et / ou commerciaux | 1 an   |
| Porte de douche                  | 10 ans |
| Roulettes et pentures            | À vie  |
| Slik stone / solide surface      | 5 ans  |
| Slik cast / fonte                | 25 ans |
| ZittaClean                       | 10 ans |
| Accessoire, drain & niche        | 5 ans  |
| Colonne de douche                | 10 ans |
| Électroniques                    | 1 an   |

Suite aux conditions et aux termes décrits ci-dessous, ZittaGroup garantit que le produit vendu est conforme à ses spécifications et qu'au moment de la vente, le produit est exempt de tout vice et/ou défaut de fabrication. Cette garantie n'est applicable que pour le premier acheteur/utilisateur et ce pour la première année à partir de la date d'achat. Cette garantie ne peut être transférée à une tierce personne. Cette garantie exclue tout frais relié au déplacement, frais d'installation et/ou désinstallation et aux frais de transport.

La présente garantie ne couvre pas les défauts ou bris résultant d'Acte de Dieu, d'accident, de catastrophe, d'abus, de négligence, d'une installation non conforme, de l'ajout ou de la suppression de pièce ou équipement, d'une mauvaise utilisation, de variation de température intense, d'exposition aux produits chimiques et a des abrasifs de tout genre ou de tache provoquée par différents types d'eau tel une eau ferreuse ou alcaline.

ZittaGroup ne peut être tenu responsable des dommages directs ou indirects causés ou résultant de cas fortuits, des frais de main d'oeuvre, frais divers, perte de temps, matériaux ou autres coûts relatifs à l'application ou au remplacement du produit ou à l'une de ses composantes. Dans l'éventualité ou un défaut de fabrication se manifeste, l'acheteur/utilisateur devra avoir suivi les instructions d'installation inscrites au manuel d'instruction, devra présenter une preuve d'achat ainsi qu'une preuve d'installation par un professionnel reconnu par l'industrie de la construction. ZittaGroup pourra à son entière discrétion, réparer ou remplacer le produit sur une base au prorata du prix alors en vigueur. ZittaGroup se réserve le droit de faire inspecter, sur le site, la défectuosité par un représentant de son choix. Aucun retour ne sera accepté sans l'autorisation au préalable de ZittaGroup.

### Nettoyage et entretien

Zitta recommande l'utilisation de détergents liquides doux pour vaisselle ou d'eau afin de garder une surface propre et brillante. Rincer très bien et assécher avec un chiffon propre. ATTENTION : Les détergents en poudre ou liquides abrasifs peuvent endommager les surfaces. Ne jamais mettre en contact avec des produits corrosifs tel que les produits de débouchage de drain. NE PAS UTILISER : Des produits nettoyants contenant des chlorures, de l'alcool, de l'ammoniac ou de l'essence minérale. De la laine d'acier, tampon à récurer ou brosses.

### ① Need help? Contact us!

☎ Tel: 1-855- 492-4242 450-704-2323  
 ☎ Fax: 1-866-735-6885  
 ✉ Info@zittagroup.com  
 🌐 www.zittagroup.com



### ① Besoin d'aide? Contactez nous!

☎ Tel: 1-855- 492-4242 450-704-2323  
 ☎ Fax: 1-866-735-6885  
 ✉ Info@zittagroup.com  
 🌐 www.zittagroup.com

